

## TM – Bottom loading arm

The TM bottom loading arms are designed for transferring dangerous fluids or gasses. They can be fitted with emergency breakaway systems and several types of couplers for easy connection to the truck/train.

### Features:

- Sizes DN50-DN200 (2"-8")
- Pressure range: 40 bar
- Temperature range: -196°C to +250°C
- Balancing by spring cylinders
- Material: available in carbon steel, stainless steel, low temperature carbon steel or special alloys

### Options:

- PTFE lining
- Jacket heating, electric tracing, insulation
- Pneumatic operation
- Vapour return line
- Emergency breakaway coupler
- Drybreak couplers
- Shut-off valves
- ...

## TM – Bottom loading arm

Bottom loading arm TM

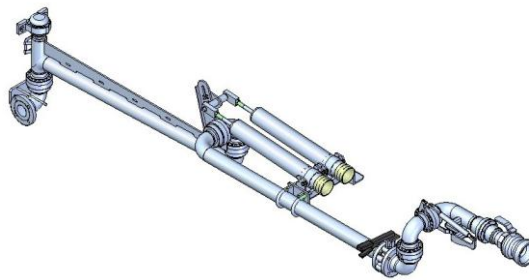

Bottom loading arm TM – internal heated

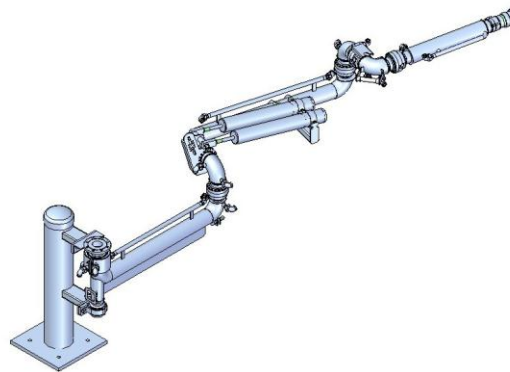

Bottom loading arm TM – piggable

